

MS-108-5



**MS-108-5**

Mains switching Reed Sensor  
pitch 20.32 mm

**Electrical Characteristics** @ 25 °C

Contact form		A
Contact rating max.	W / VA	10
Switching voltage max.	VDC	200
	VAC	260
Switching current max.	A	0.3
Carry current max.	A	1.4
Breakdown voltage min.	VDC	400
Total resistance max. (initial)	mΩ	100
Insulation resistance min.	Ω	10 <sup>10</sup>

**Features**

- > Mechanically protected
- > Mains switch inside
- > Various sensitivity ranges available
- > Customized types available

**Magnetical Characteristics (of unmodified Reed Switch)** @ 25 °C

Pull in range available	AT	15 - 30
Drop out min.	AT	4
Test coil	TC	200
Test equipment tolerance	± AT	2

**Approvals**



**Operating Characteristics (of unmodified Reed Switch)** @ 25 °C

Switching frequency max.	Hz	400
Resonant frequency typ.	Hz	4000
Operate time max. (incl. bounce)	ms	0.6
Release time max.	ms	0.2

**Environmental Characteristics**

Operating temperature	°C	-20 to +85
Vibration (50-2000 Hz)	g	30
Shock (1/2 sin 11 ms)	g	100

**Dimensions in mm**

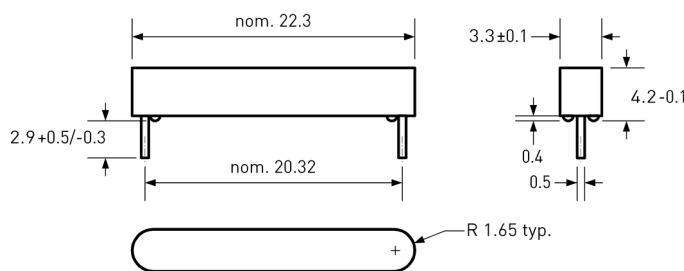

**Ordering Information**

Packing Unit	500 pcs
Weight per piece	0.42 g
Weight per package	255 g
Standard AT Ranges	
	2 = 15 to 20 AT
	3 = 20 to 25 AT
	4 = 25 to 30 AT

**Ordering Example**

MS-108-5-2 describes MS-108-5 with 15 to 20 AT.

MS-108-5



**MS-108-5**

Mains switching Reed Sensor  
pitch 20.32 mm

Material Information

	Material	Colour
Housing	PA-GF	black
Potting compound	Epoxy	black

Test Procedure of final Reed Sensor

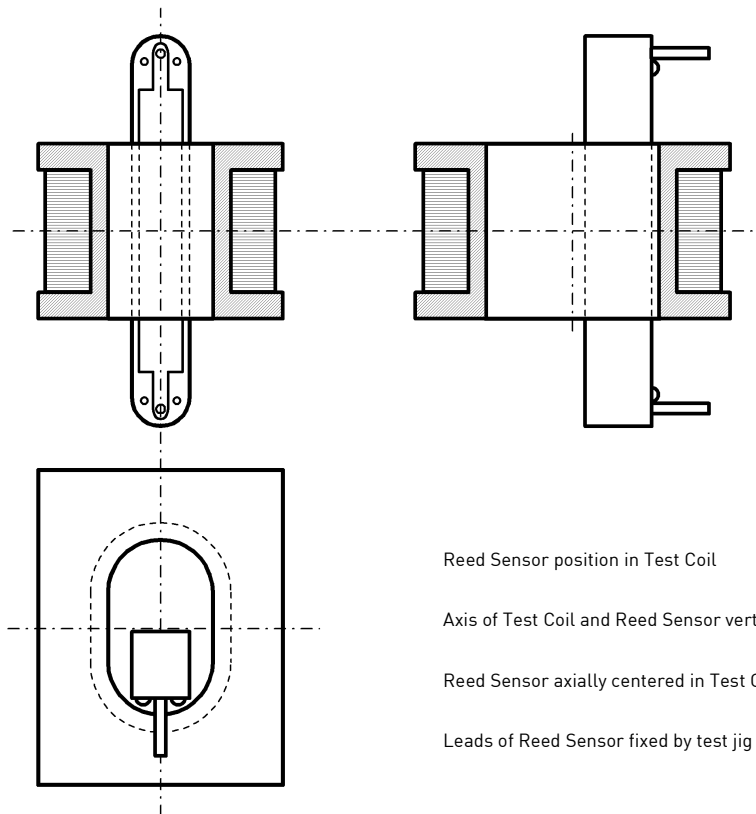

- Reed Sensor position in Test Coil
- Axis of Test Coil and Reed Sensor vertical
- Reed Sensor axially centered in Test Coil
- Leads of Reed Sensor fixed by test jig

Test Parameters

Test coil	TC-307
Test programs	
AT range	Test program
2 =	MS-108-5-2
3 =	MS-108-5-3
4 =	MS-108-5-4

Remarks

When mounted onto ferromagnetic parts switching distance of MS-108-5 may reduce. Electromagnetical influences and magnetic fields may change the switching behaviour of the sensor.